

Hako Citymaster 1250



General information

- Objective
- Models
- Registration

Details

- Driver's cab
- Appearance & function
- Technical data

Product structure & prices



General information

Objective

- **CM 1200 model upgrade**
taking into account the following priorities

General information

Objective

Registration
Models

Details

Driver's cab
Appearance & function
Technical data:

Product structure &
prices

- Improving the driver convenience
- Increase the Efficiency
- Increase the serviceability and reliability

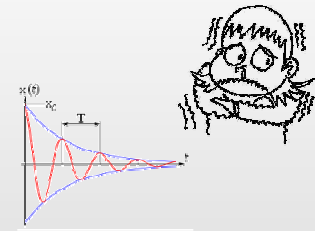



General information

Objective

General information

Objective

Registration

Models

Details

Driver's cab

Appearance & function

Technical data:

Product structure & prices

• Convenience

- Drivability
 - increased driving speed
 - new seats for improved suspension
- Driver's cab & heating
 - foot area heater outlet
 - increased windscreen wiper panel

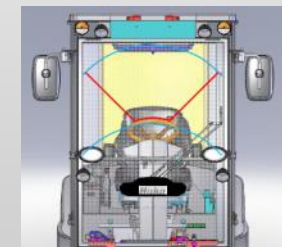

General information

Objective

General information

Objective

Registration

Models

Details

Driver's cab

Appearance & function

Technical data:

Product structure & prices

• Convenience

• Tool&Attachment change system

- Improvement of the bolt system on tool-free design
- Detail improvements (e.g. platform)
- Revised operator's manual

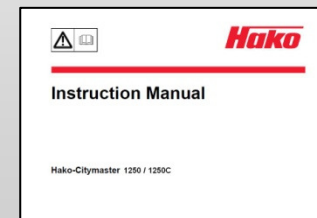
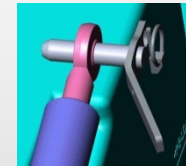



General information

Objective

• Efficiency

- time saved by higher transport and working speed (30 / 16 km/h)
- faster change of rear implements due to improved bolt-system
- new product structure → customers only buy what they actually need

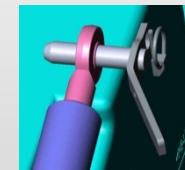

General information

Objective

Registration
Models

Details

Driver's cab
Appearance & function
Technical data:

Product structure & prices

General information

Objective

General information

Objective

Registration

Models

Details

Driver's cab

Appearance & function

Technical data:

Product structure & prices

• Serviceability

- new radiator with greater passage and finer air intake screens
- lubrication aid (standard)
→ lubrication points of front lift accessible
- New cover for the engine air intake and deflectors on the hopper

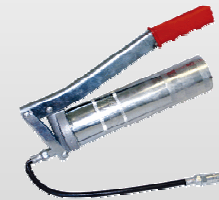
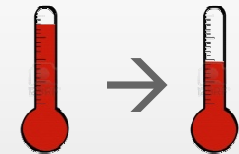

General information

Type of licence

- Machine will be licenced as farming & forestry tractor
→ international permit easier to obtain
- Driving licence class B (national class L)
- Design changes due to type of licence and higher vehicle speed
 - lights moved further down
 - brake with stricter requirements
 - towing eye at front
 - compulsory towing device

General information

Objective

Registration

Models

Details

Driver's cab

Appearance & function

Technical data:

Product structure & prices

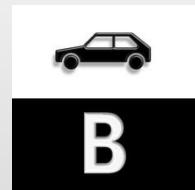

2003/37/EG

General information



Type of licencing

- Insurance (example Germany)

- compulsory licence means compulsory insurance (liability) and compulsory licence plate
- annual liability insurance premium
 - working machine : 1500 € to 2000* €
 - tractor: 600 € to 800* €



→ significant cost savings* !

*: Example of current query in Germany

General information

Objective

Registration

Models

Details

Driver's cab

Appearance & function

Technical data:

Product structure & prices

General information



Type of licencing

• Tax

- no tax for self-propelled working machine
- tractor licence incurs taxes:
12.02 € per 200 kg of weight
(2600 kg / 200 = 13)
13 * 12.02 € = **156.26 €*** per year



For exclusive use of the street cleaning (also winter service) and appropriate labeling the tractor is also tax-free!

*: Germany



Winter Service

General information

Objective

Registration

Models

Details

Driver's cab

Appearance & function

Technical data:

Product structure & prices

Hako-Citymaster 1250 / 1250C

General information



Models

General information

Objective
Registration

Models

Details

Driver's cab
Appearance & function
Technical data:

Product structure &
prices





General information

Models

- Citymaster 1250
• single-purpose machine **99 1433 21**
- Citymaster 1250**C** (C = carrier)
• multipurpose machine **99 1433 31**

General information

Objective
Registration

Models

- Both models available as
Comfort (air-conditioned) or Classic
variants **xx xxxx 22**
xx xxxx 32

Details

Driver's cab
Appearance & function
Technical data:

- City cleaner may be used with the
wet cleaning package option **99 1463 02**

Product structure & prices

Details

Product structure & prices

General information

Objective

Models

Registration

Details

Driver's cab

Appearance & function

Technical data:

Product structure & prices

- CM1250
 - basic single-purpose road sweeper without lighting, seat, wheels and sweeper unit
- CM 1250C
 - same as CM 1250 plus:
 - extended hydraulic system (working hydraulics at front, control hydraulics and hydraulic actuators at rear)
 - differential lock
- Dirt hopper and sweeper unit available as separate options

Details

Product structure & prices

General information

Objective

Models

Registration

Details

Driver's cab

Appearance & function

Technical data:

Product structure & prices

- Multipurpose package discontinued in favour of separate options
- Multipurpose wet cleaning package still required for City-Cleaner
- Differential lock available as separate option for CM1250
- path-dependent spreading no longer available, but:
 - path signal transmitter linked to sweeping mileage counter
- Ordering examples will be added to the price list in future



Details

Product structure & prices

- Price list (list prices)

Hako-Citymaster 1250 Classic: from 70.700,- €*
Hako Citymaster 1250C Classic: from 73.350,- €*
additional charge „Comfort“: 1.800,- €
additional charge „C“: 2.650,- €

General information

Objective

Models

Registration

Details

Driver's cab

Appearance & function

Technical data:

*: Complete unit consisting of: basic vehicle, lighting, standard tyres, sweeper, broom, hopper

Product structure & prices

Start of production: 03/2012

Start of delivery: week 17/24 of 2012



Details

Technical data

General information

Objective

Models

Registration

Details

Driver's cab

Appearance & function

Technical data:

Product structure & prices

- Gross total weight: +100 kg
2600 kg
- empty weight +~85 kg
- Rear axle load 1600 kg
- Working speed 16km/h
- Driving speed: 30 km/h
- Height: 1999 mm
(unchanged)

Details

Driver's cab

General information

Objective

Models

Registration

Details

Driver's cab

Appearance & function

Technical data:

Product structure & prices

- Entire cabin “ROPS”-tested
 - highest level of security
 - secured headroom
 - tested seat anchorage points
- Steering column adjustment (standard at all CM 1250)
 - uniform level of comfort
- New, air-suspended “Grammer”-seat
 - standard with belt
 - improved vibration characteristics
 - improved coordination to vehicle
 - advanced features (backrest, setting)

Hako
Clean ahead



Details

Driver's cab

- Heated foot area
 - Redirection of the thermal heat downside
 - Improvement of winter properties

General information

Objective

Models

Registration

Details

Driver's cab

Appearance & function

Technical data:

Product structure &
prices

left



right

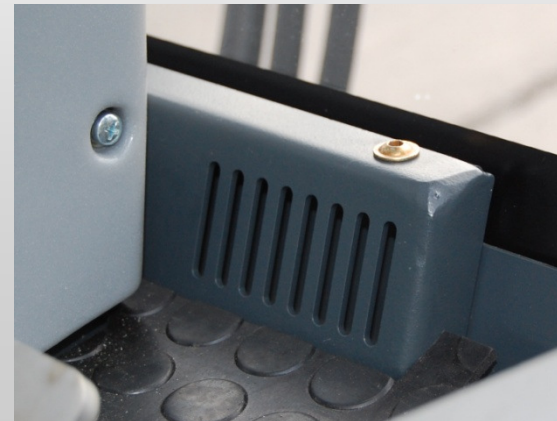

Details

Driver's cab

- Re-arranged controls on the right-hand panel
 - extended options
 - uniform switch arrangement

General information

Objective

Models

Registration

Details

Driver's cab

Appearance & function

Technical data:

Product structure & prices



Hako-Citymaster 1250 / 1250C



Details

Driver's cab

- Door pocket on left-hand side
- additional storage

General information

Objective

Models

Registration

Details

Driver's cab

Appearance & function

Technical data:

Product structure & prices



Details

Appearance & function

General information

Objective

Models

Registration

Details

Driver's cab

Appearance & function

Technical data:

Product structure & prices

- New outer roof



- New windscreen wiper with intermittent control
- New mirrors (optional: heated)

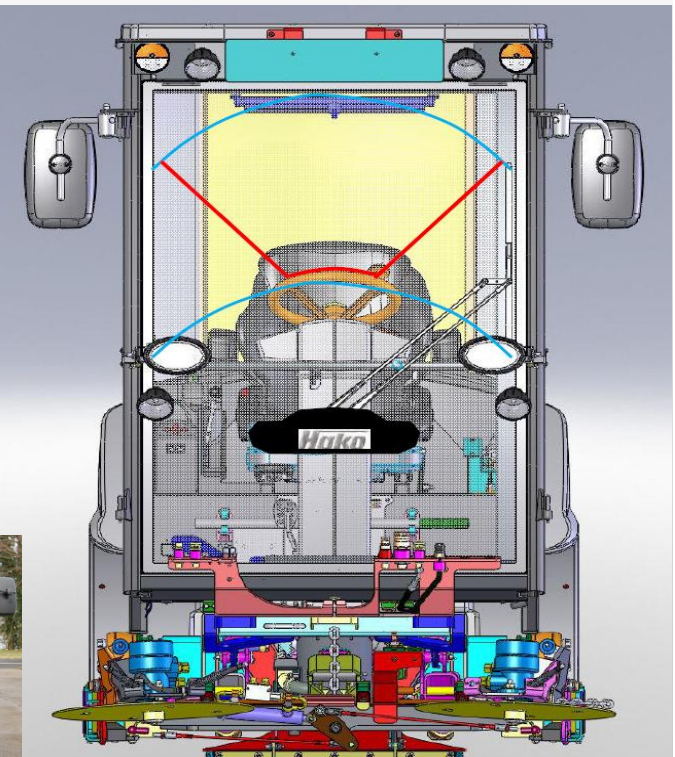

Details

Appearance & function

General information

Objective

Models

Registration

Details

Driver's cab

Appearance & function

Technical data:

Product structure & prices

- New lighting
 - headlights
 - working lights
 - auxiliary work lights
- New mirrors (CM 2000)
 - solid support
 - larger
 - heated as option

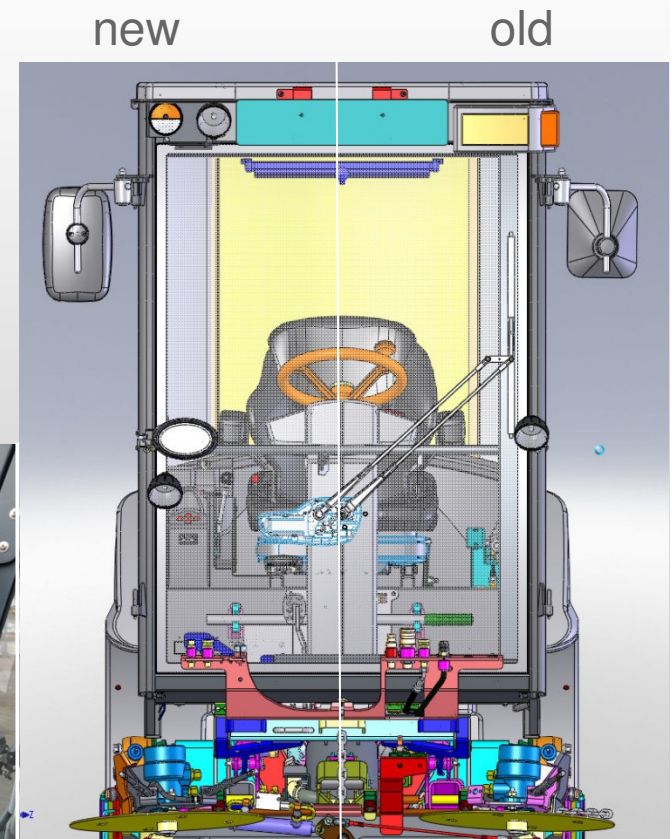

Details

Appearance & function

General information

Objective

Models

Registration

Details

Driver's cab

Appearance & function

Technical data:

Product structure & prices

- New exhaust pipe to raise less dust and dirt



- Towing eye
 - required for the tractor homologation
 - limited accessibility with mounted implements
- Trailer coupling

Details

Appearance & function

General information

Objective

Models

Registration

Details

Driver's cab

Appearance & function

Technical data:

Product structure & prices

- Loading platform
 - easier assembly:
 - lift cylinder used as support
 - roller stand

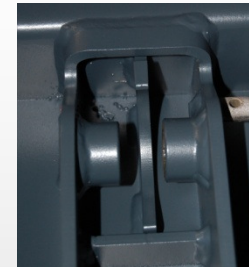

- Locking pins for platform and dirt hopper
 - mounting without tools

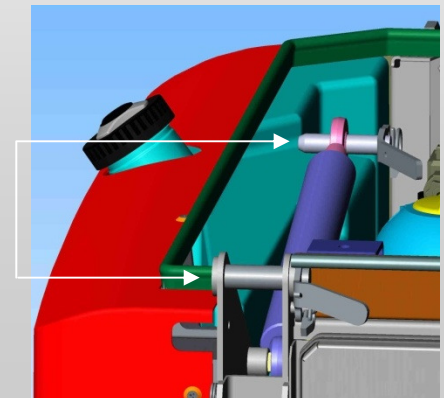
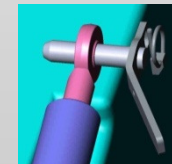

Details

Appearance & function

General information

Objective

Models

Registration

Details

Driver's cab

Appearance & function

Technical data:

Product structure & prices

- Radiator:
 - larger mesh size
 - lower dirt intake
 - easier cleaning
- Radiator screens:
 - smaller holes but increased total throughput
 - effective pre-separation
 - sieve-door back (standard)
plate cover for winter operation

Hako
Clean ahead

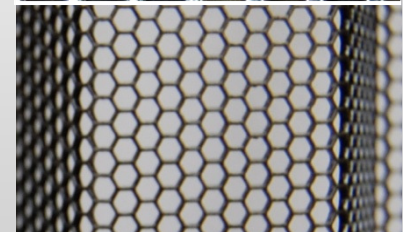
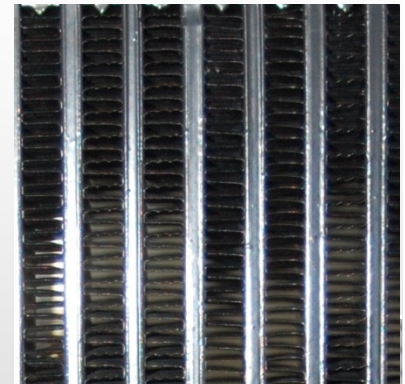

Details



Appearance & function

General information

Objective

Models

Registration

Details

Driver's cab

Appearance & function

Technical data:

Product structure & prices

- New final drive with Radial piston wheel drives
 - Increased speed 30 km/h
 - High efficiency compensates increased transmission ratio compared to G-roller engines Citymaster 1200
 - Unchanged drive-pump and control

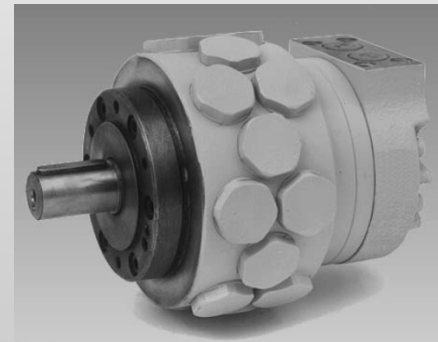
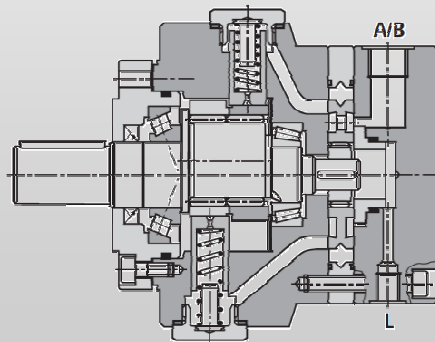
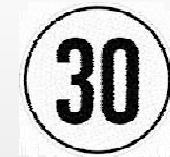

new



old

Details

Appearance & function

General information

Objective

Models

Registration

Details

Driver's cab

Appearance & function

Technical data:

Product structure & prices

- Lubrication assistance
 - lubrication points of front lift extended (standard)
 - expandable with "easy-grease" option (1 grease point to serve 8 grease places, front-lift, vehicle articulation)
 - compatible with central lubrication

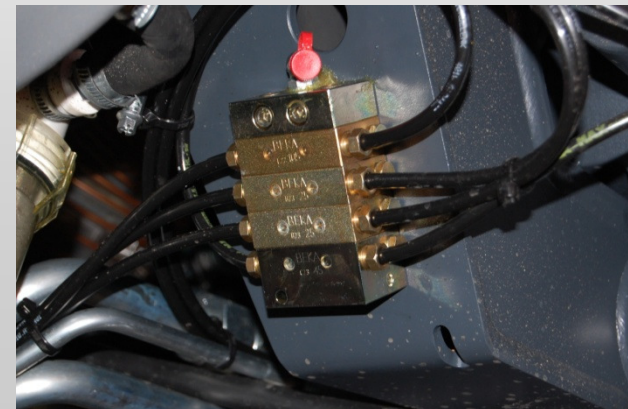

Details

Appearance & function

General information

Objective

Models

Registration

Details

Driver's cab

Appearance & function

Technical data:

Product structure & prices

- Dirt hopper load level indication (optional)
 - Visual display in the cab after reaching the allowed load level

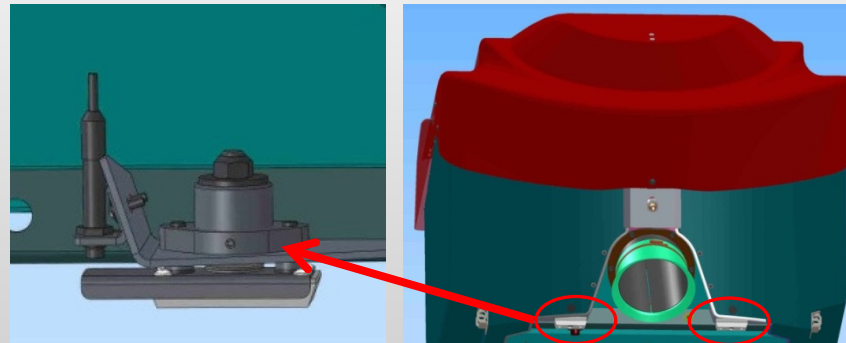

- acoustic and luminous signal



Hako-Citymaster 1250 / 1250C

Details



Appearance & function

General information

Objective

Models

Registration

Details

Driver's cab

Appearance & function

Technical data:

Product structure & prices

- SOW option external dirt water drain hose

